

Energy Absorption of 3D Printed Auxetic Lattice Under High-Impact Loading

Joshua Kelly, Silas Johnson, Department of Mechanical Engineering, University of New Hampshire



Introduction

- Impact Resistance is critical in structural and protective applications
- Lattice geometry strongly influences deformation and fracture behavior
- Certain common structures exhibit **auxetic behavior** under impact

$$\nu = -\frac{\epsilon_{\text{transverse}}}{\epsilon_{\text{axial}}}$$

Poisson's ratio

transverse (lateral) strain

axial (linear) strain

Auxetic: a structure possessing a negative Poisson's ratio

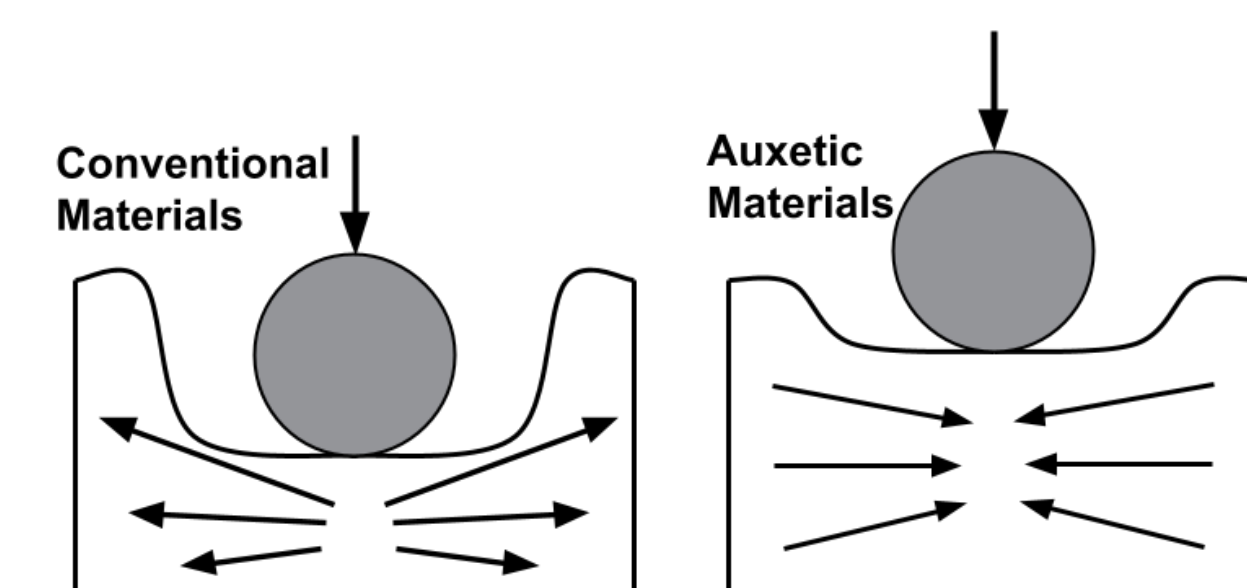

- Additive manufacturing enables the quick and cheap fabrication of complex internal lattice geometries that can significantly influence mechanical performance.
- This study investigates the effect of commonly used auxetic structures on energy absorption under Izod impact loading conditions.



Objectives

- Compare impact energy absorption across multiple common lattice structures that exhibit auxetic behavior
- Determine which of the tested lattice geometries maximizes energy absorption in impact loading scenarios
- Assess the relationship between geometry and mechanical performance

Methods

Specimen Design

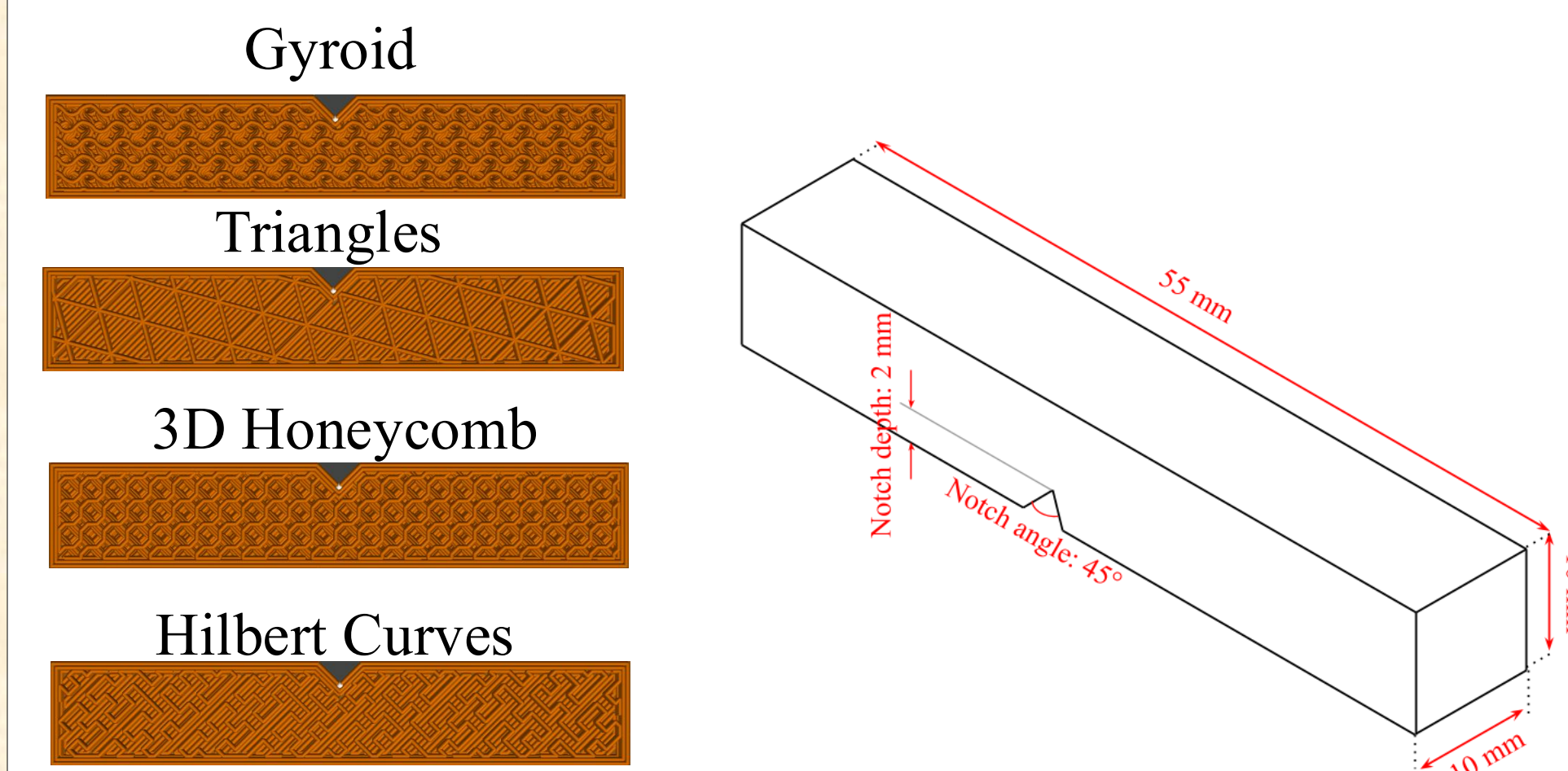

Izod High-Impact Loading

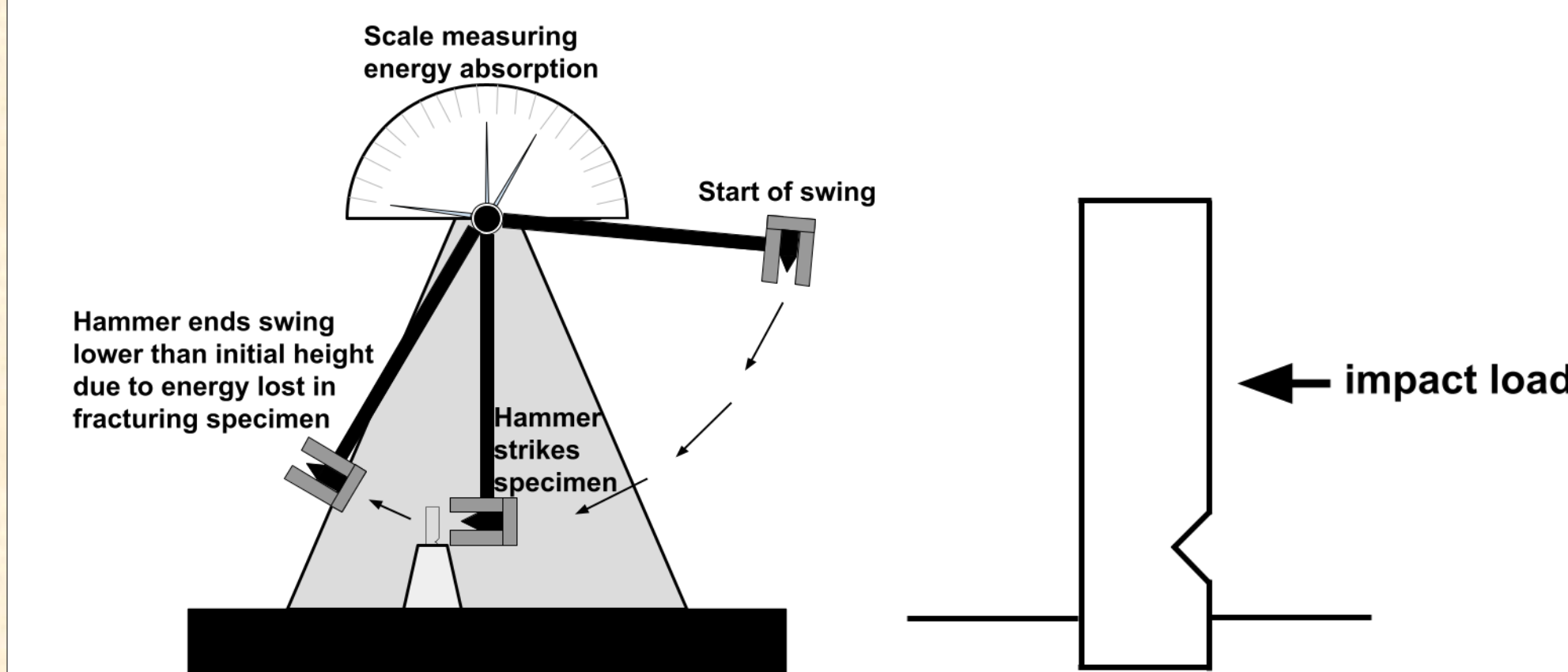

- n = 10 specimens per lattice type; m = 4 g for all specimens
- Energy absorption of each specimen recorded for analysis, along with other relevant observations related to the fracturing

Results

Lattice Structure	Infill Density	Average energy absorption per specimen (J)	Standard Deviation of energy absorbed (J)	Specific Energy absorption, SEA (J/g)
Gyroid	31%	0.629	0.054	0.15725
Triangles	29%	0.746	0.091	0.1865
3D	31%	0.823	0.093	0.20575
Hilbert	28%	0.617	0.068	0.15425
Control	28%	0.639	0.029	0.15975

- Honeycomb achieved the highest energy absorption and SEA, indicating superior impact performance among tested lattices.
- Consistent fracture behavior correlated with reliable performance, as seen in gyroid and control samples.
- High-performing structures exhibited controlled deformation prior to fracture, allowing greater energy dissipation.

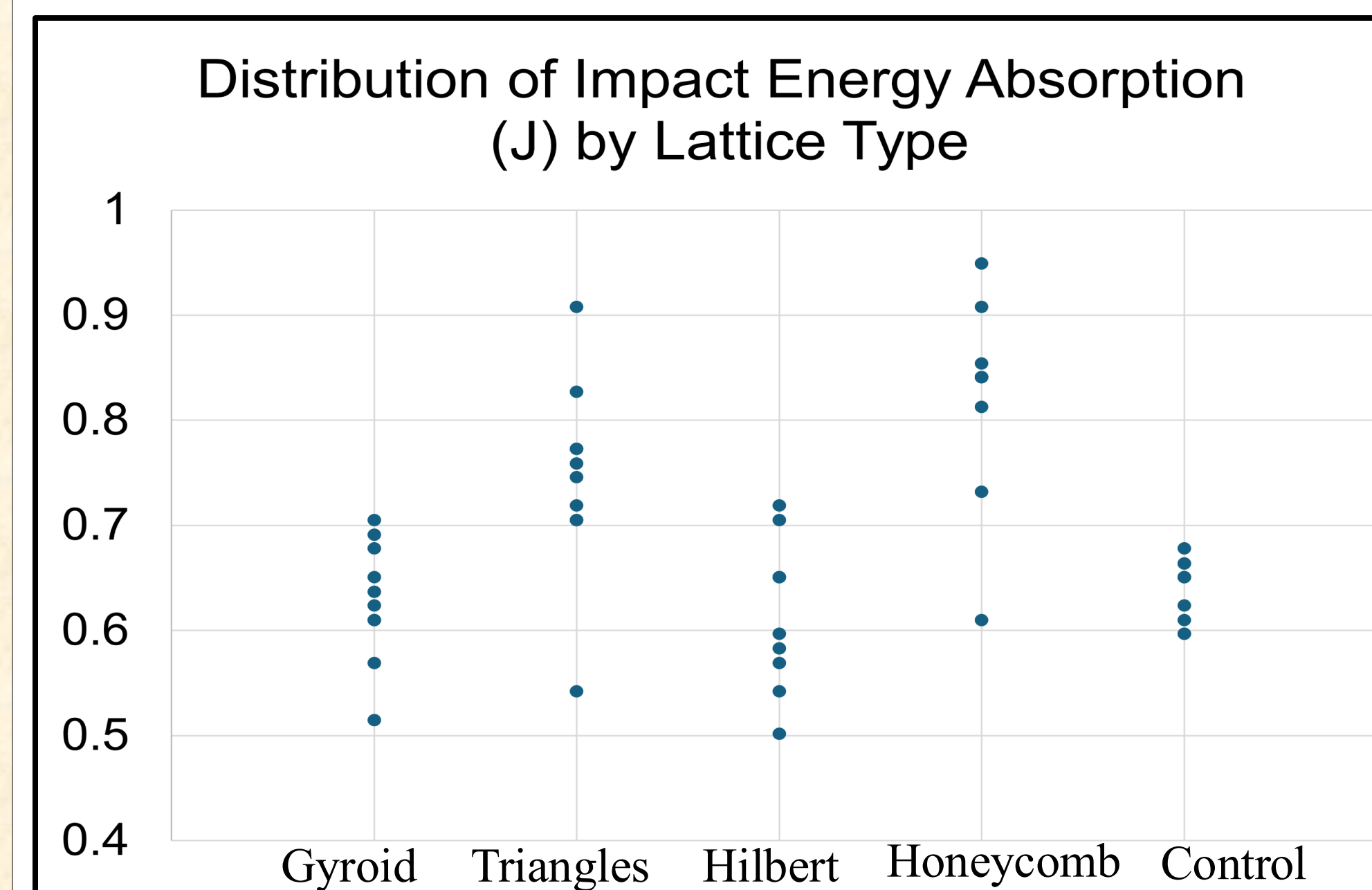
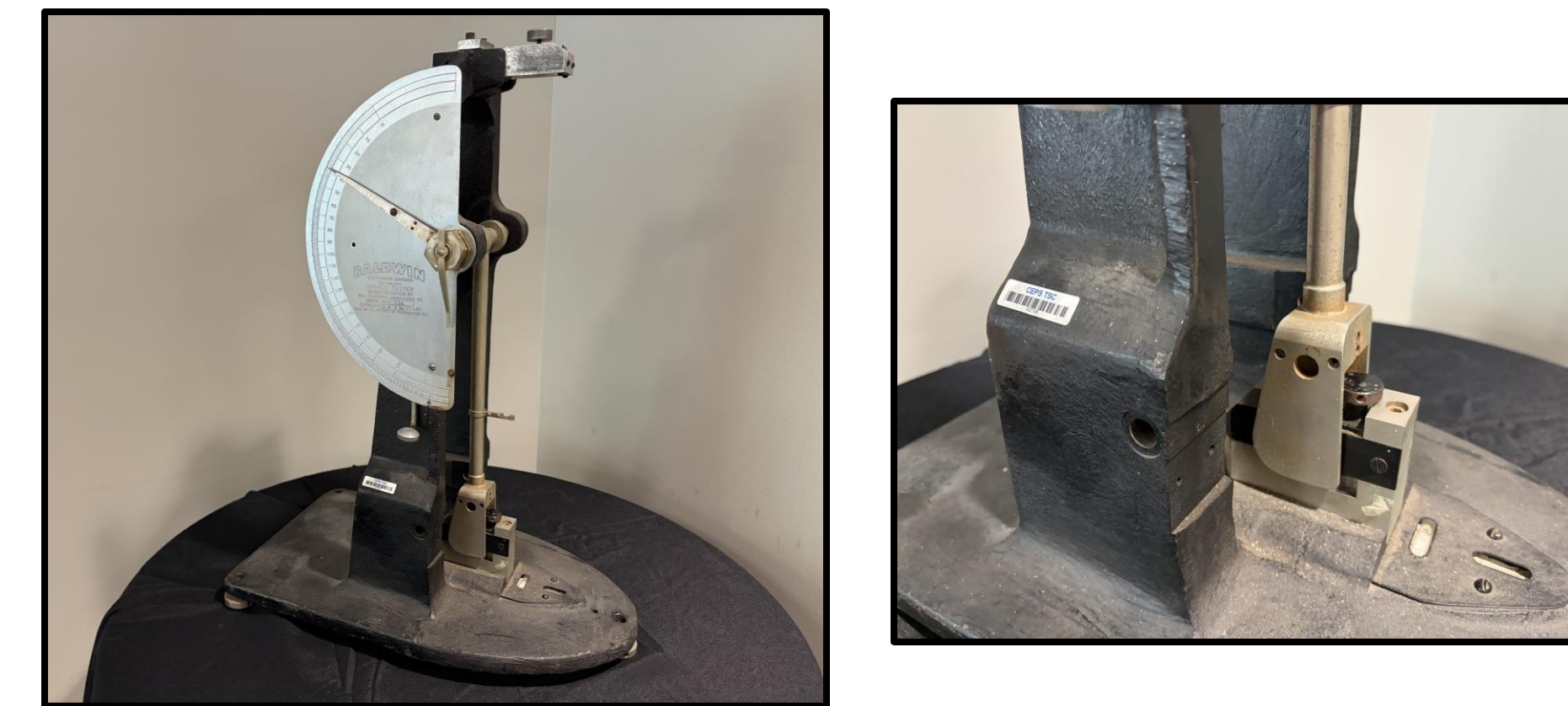

Lattice Type	Fracture Photo	Fracture Mode
Gyroid		Uniform brittle fracture
Control		Brittle fracture with minor internal tearing
3D honeycomb		Controlled structural collapse
Triangles		Controlled but irregular fracture
Hilbert		Unstable failure

Conclusions

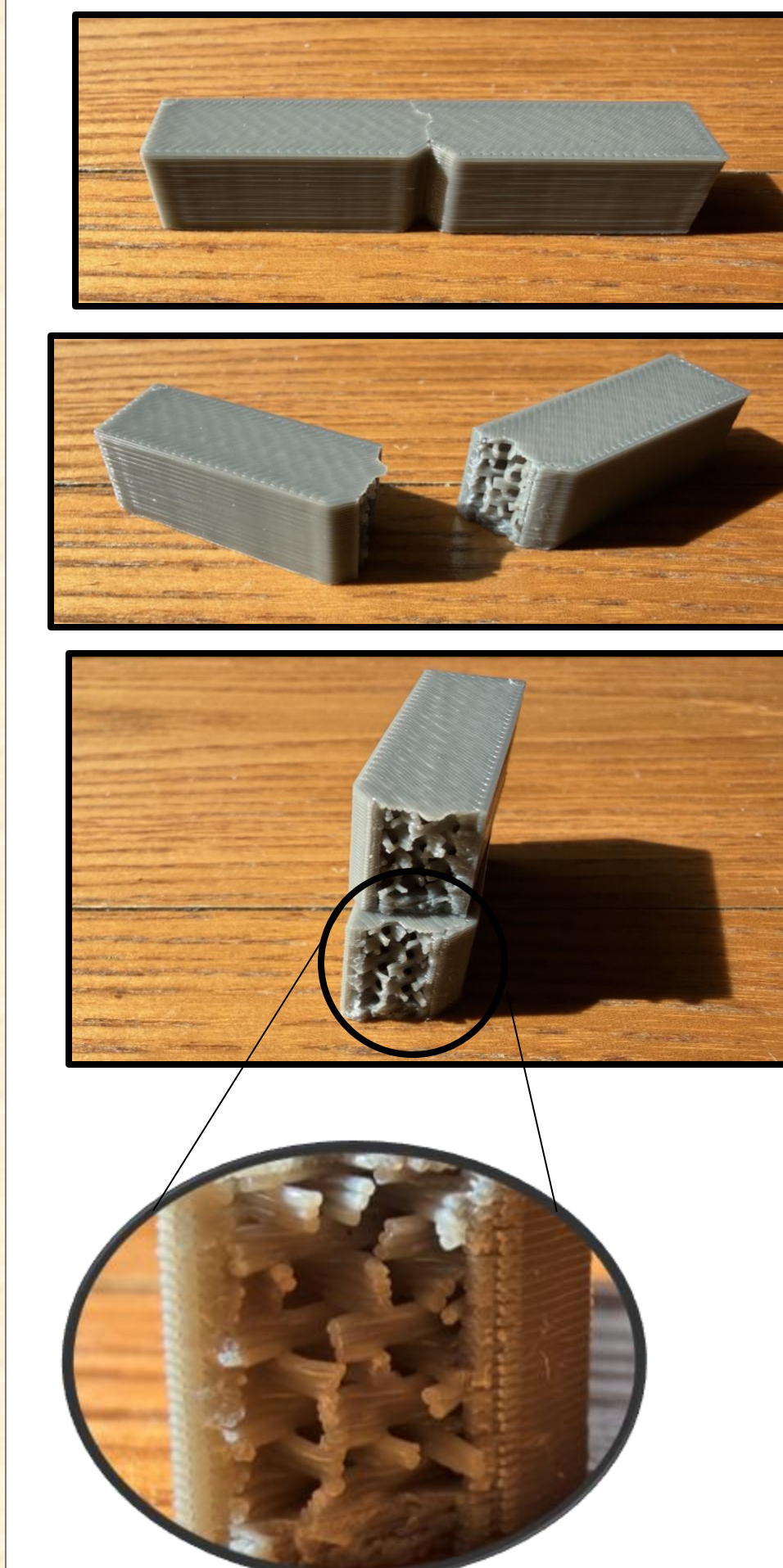

- Lattice geometry strongly influences impact performance, with 3D connectivity providing the most effective energy dissipation.
- Unpredictable crumpling may be beneficial in controlled applications (e.g., crumple zones), but inconsistent behavior reduces reliability when energy absorption is lower.
- Optimal impact-resistant designs balance high energy absorption with predictable, controlled failure mechanisms.

Next Steps



Rough prototype of TPU (flexible 3D printer filament) Izod test specimens

- Compare different materials (PLA vs TPU)
- Incorporate high-speed imaging of fracture behavior
- Investigate effect of relative density on performance

References

ASTM E23, *Standard Test Methods for Notched Bar Impact Testing of Materials*, ASTM International.

Ansari, A. A., & Kamil, M. (2022). *Izod impact and hardness properties of 3D printed lightweight CF-reinforced PLA composites*. *International Journal of Lightweight Materials and Manufacture*, 5(3), 369–383.