

## PROBLEM

It is difficult for beginner guitarists to replicate a guitar's tone (how it sounds) heard live or in a recording due to lack of knowledge on what equipment to purchase and how to configure it.

## GOAL

Create a combo amplifier that accepts a recording of an electric guitar's sound and allows an electric guitar to be played such that the tone heard in the recording is copied.

# Pedal Parrot: Effect Mimicking Electric Guitar Amplifier

Paige McAfee, Advisor: Dr. Wayne Smith

## HOW TO USE

- 1 Upload recording via USB drive
- 2 Wait for amp to analyze effects
- 3 Play guitar, which will have same tone as recording

### TYPICAL ELECTRIC GUITAR SET UP

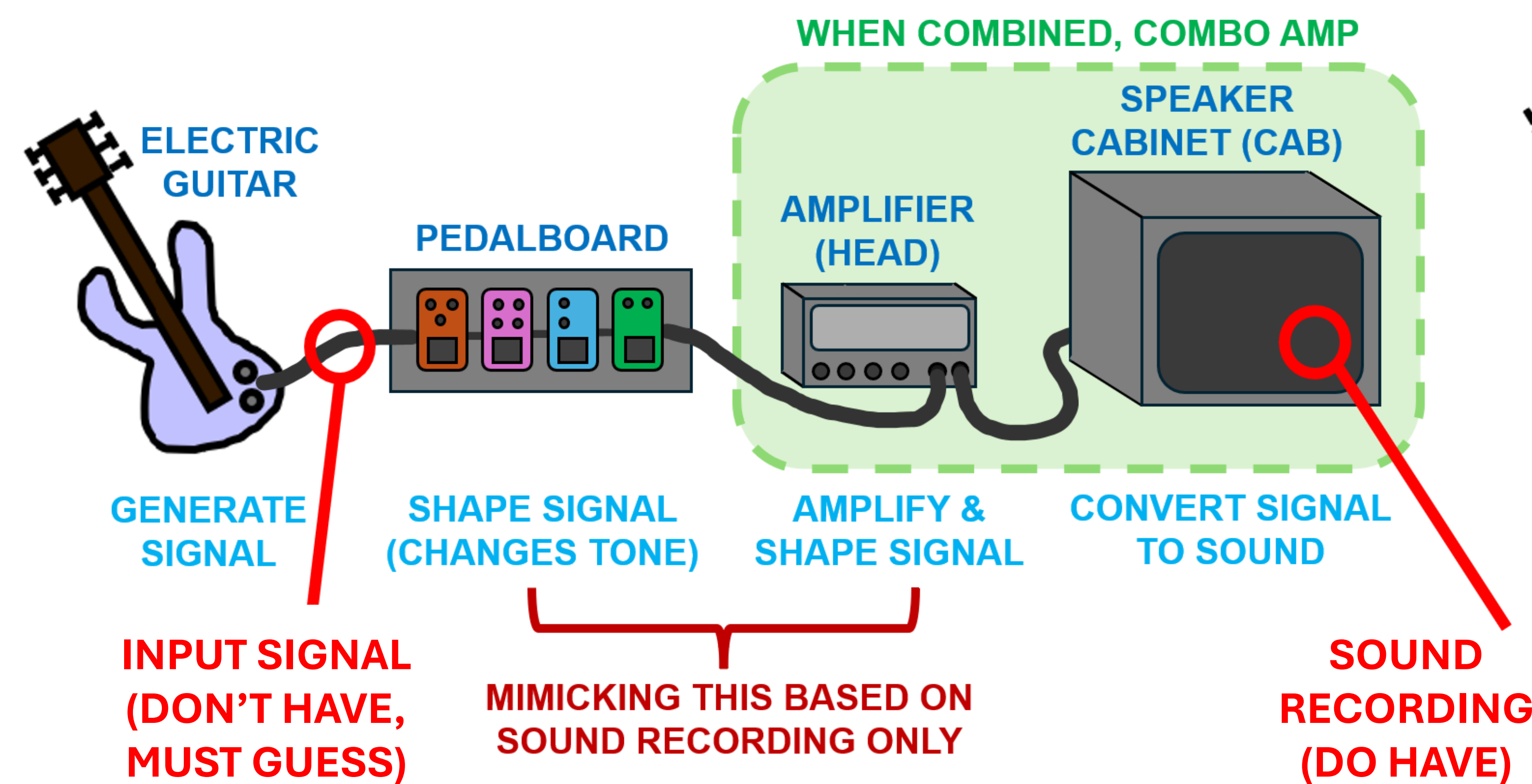

### PEDAL PARROT SET UP

