

# FLASH – Field-deployable Lightning Analysis System using High-speed RF



Joshua D'Addario (Lead Author), Stephen Horn (Co-author), Dr. Ningyu Liu (Project Advisor), Department of Physics & Astronomy, UNH {Joshua.DAddario, Stephen.Horn, Ningyu.Liu}@unh.edu

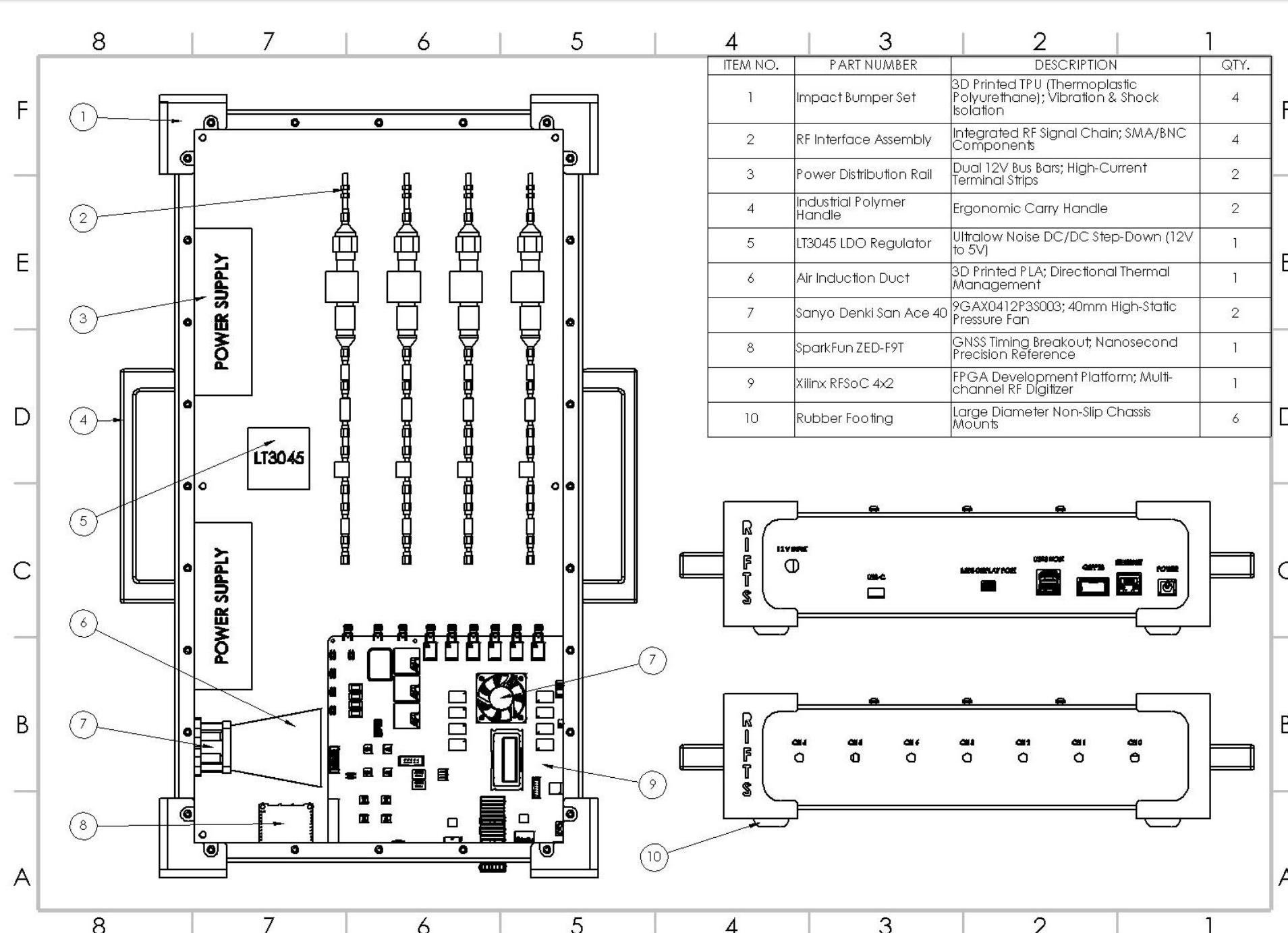
## Background & Motivation

- **Environmental Limitations:** Cloud cover and storm dynamics limit lightning studies; RF (radio frequency) detection enables all-weather, pre-flash measurements but **requires EMI (electromagnetic interference) shielding** for sensitive electronics.
- **Portability & Integration Gap:** RF systems are bulky; Reliable & ready acquisition favors a mobile platform with EMI shielding and **weatherproof site hardware.**

## Design Objectives

- **RF Integrity:** Engineer an RF-tight enclosure for the RFSoc (Radio Frequency System-on-Chip) 4x2 platform to **minimize signal noise** during high-energy events, while **precisely modeling cutouts for manufacturing to accommodate the board's specific ports**—balancing tight tolerances with EMI shielding to mitigate leakage at interface boundaries.
- **Environmental Resilience:** Develop an **IP67-rated** OmniLOG® antenna mount capable of sustained field deployment in severe weather.
- **Rapid Deployment:** Design a portable, modular system to transition from stationary labs to **mobile** research locales.

## Ruggedized RFSoc 4x2 Field Enclosure



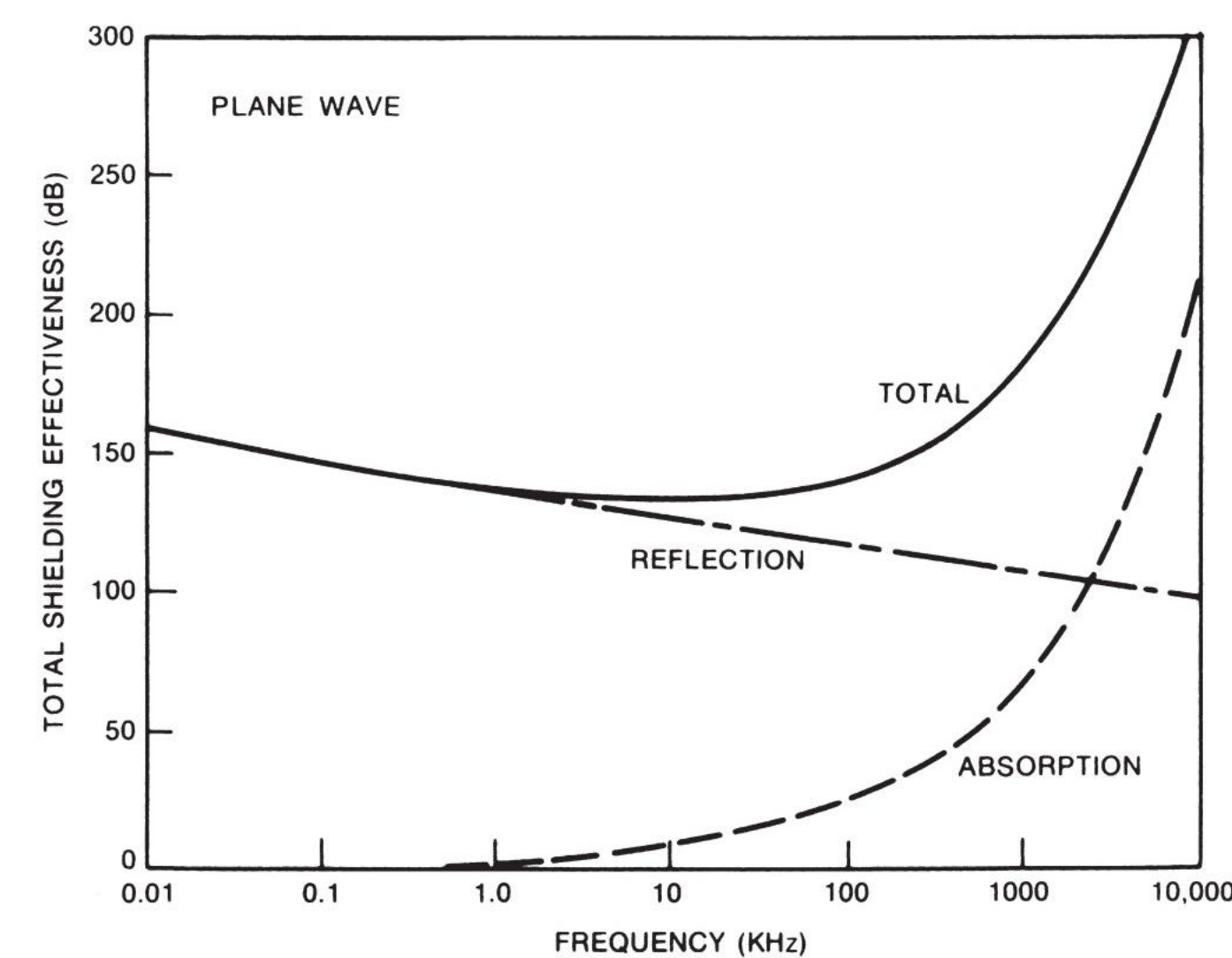
**Figure [1]: Ruggedized FLASH Enclosure Assembly.** An integrated field instrument featuring precision GNSS timing and custom 3D-printed thermal and impact protection for lightning research.



**Figure [2]: High Quality Render.** Isometric FLASH enclosure.

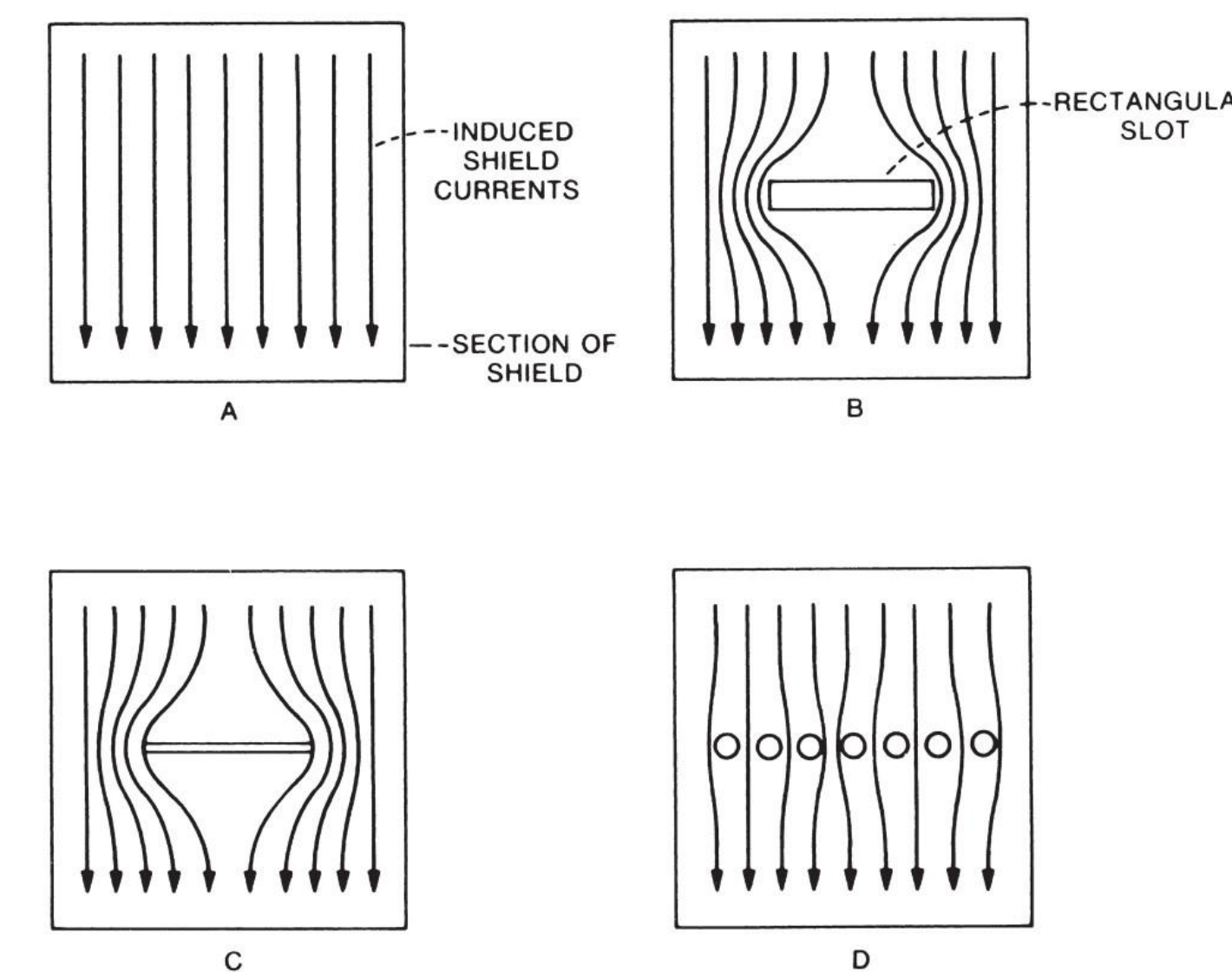
- **Shielding & Construction:** Fabricated from **0.064" 5052 Aluminum** with **continuous seam welds** and high-density screw spacing to eliminate seam-antenna effects (see Figure [5]) and maximize EMI attenuation.
- **Thermal Architecture:** Replaced stock cooling with **dual 19.1 – 80.4 CFM (cubic feet per minute) fans** and **3D-printed air ducts**, ensuring laminar flow across the RFSoc's processing cores during high-duty cycles.
- **Mechanical Resilience:** Integrated **3D-printed TPU (thermoplastic polyurethane) corner pads** and ergonomic handles for vibration isolation and rapid deployment in varied terrain.

## Shielding Theory

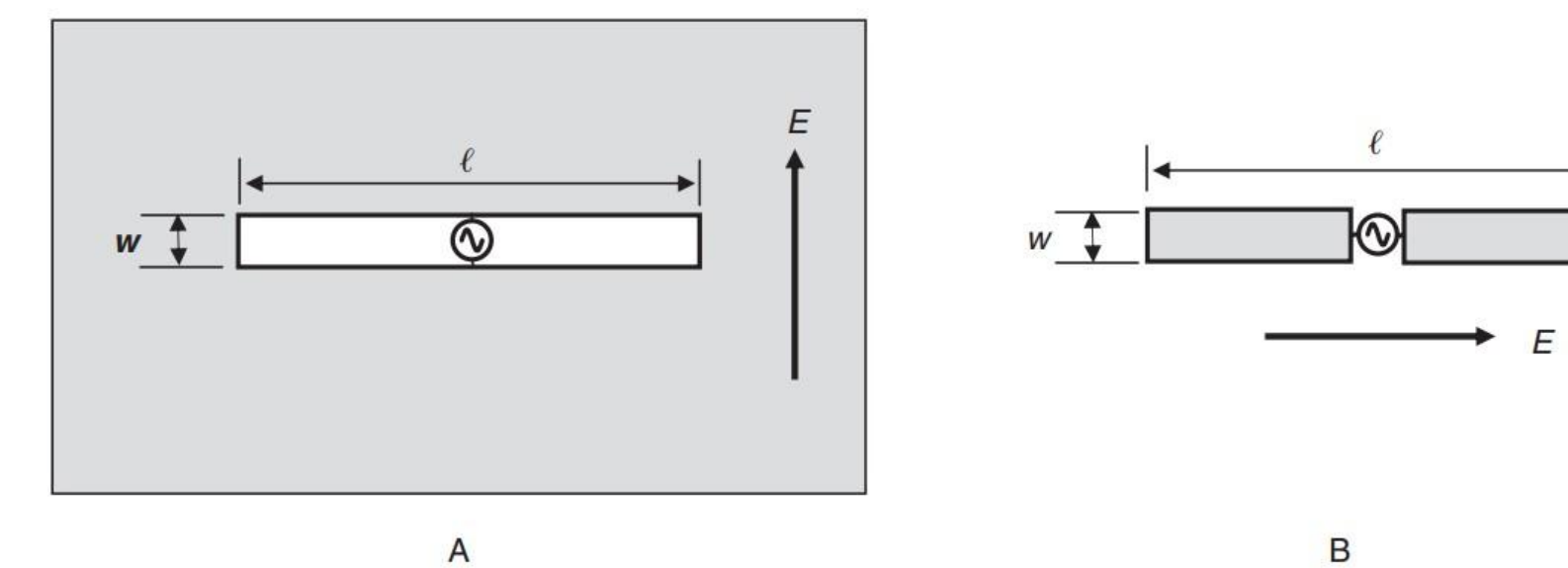


**Figure [3]: Total Shielding Effectiveness vs. Frequency.** Far-field shielding effectiveness of 0.02" copper [1].

- **S = A + R dB:** Shielding effectiveness (S) is the sum of absorption (A) and reflection (R); thickness > skin depth = attenuation [1].
- **Aperture Theory:** Shielding is affected by the ratio of wavelength ( $\lambda$ ) to gap size (L). Attenuation is maximized when  $L \ll \lambda$  preventing apertures from acting as slot-antennas [1].

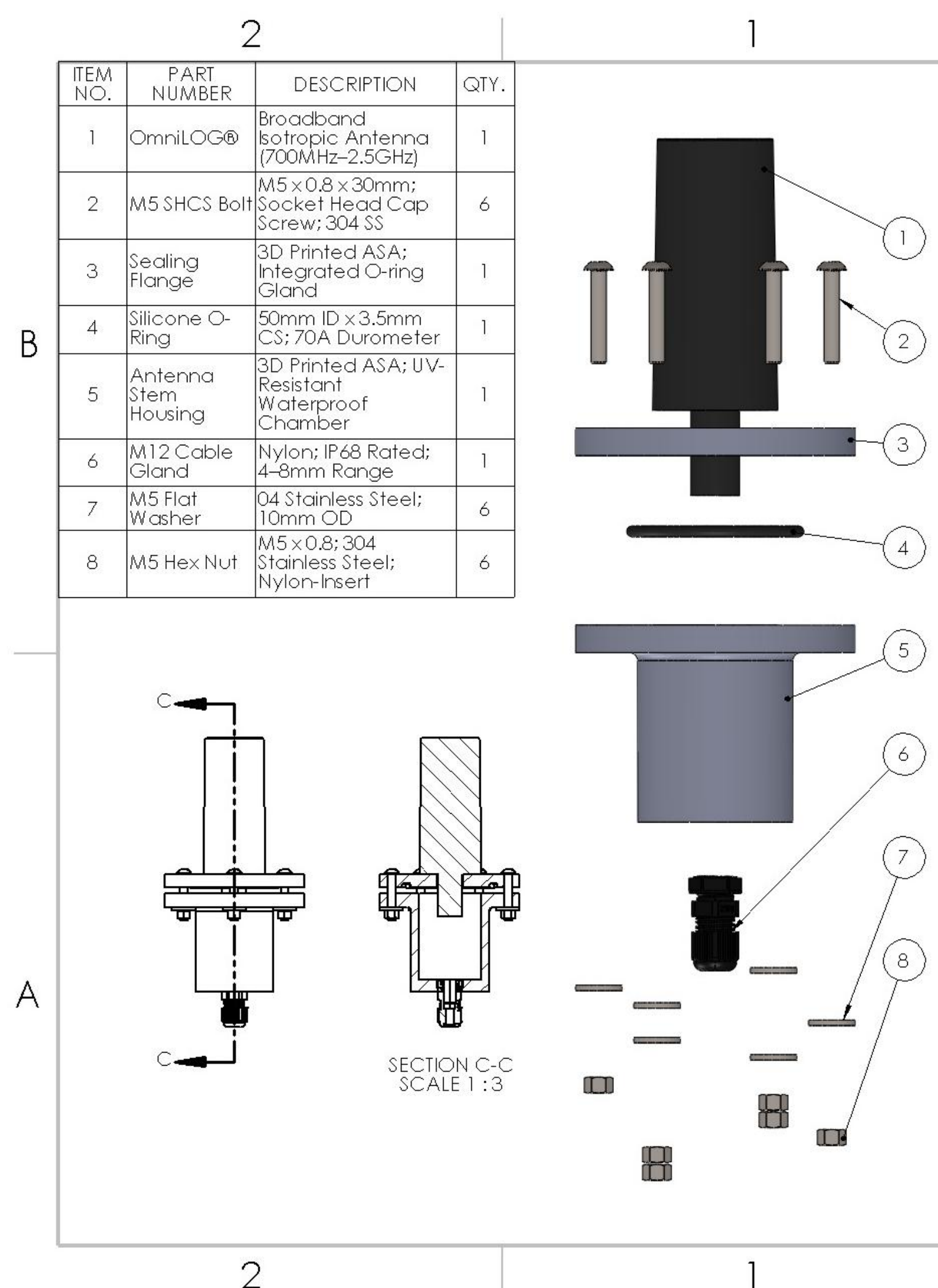


**Figure [4]: Circuit Theory Approach.** Effect of shield discontinuities on induced current distributions [1].



**Figure [5]: Slot-Antenna Theory.** (A) A seam and (B) its complementary dipole antenna (Reprinted from [1]).

## Engineering a Field-Deployable Antenna Interface



**Figure [6]: FLASH Antenna Mount Assembly.** An IP67-rated, 3D-printed housing featuring a custom O-ring seal and M16 cable gland to protect the OmniLOG® antenna in rugged field environments.



**Figure [7]: IP67 Submersion Test.** The 3D-printed antenna chamber held over a custom-built 1-meter water column to validate seal integrity and hydrostatic pressure resistance for 30 minutes.

- **Environmental Hardening:** Transitioned from PLA (polylactic acid) prototypes to production-grade ASA (acrylonitrile styrene acrylate) for long-term **UV stability.** Applied silicone grease to O-ring seal to effectively mitigate potential leak paths and ensure the **waterproof integrity** of the 3D-printed enclosure.
- **Precision Compression Architecture:** Optimized O-ring groove geometry in SolidWorks for a **zero-leak radial seal.** M5 stainless hardware and a concentric sealing stem maintain a constant-pressure interface, preventing moisture/dust ingress during outdoor thermal cycling.

## Results

- **EMI Mitigation:** A shielded chassis and **precision-modeled apertures** create a "Faraday cage" effect, maintaining the nanosecond timing accuracy required for high-speed RFSoc 4x2 broadband signal digitization and transient radio frequency capture.
- **IP67 Environmental Sealing:** An integrated O-ring gland and compression-sealed antenna housing **isolate the signal chain from moisture**, ensuring hardware reliability during rigorous 1-meter hydrostatic field tests conducted for atmospheric research.

## References

- [1] H. W. Ott, *Electromagnetic Compatibility Engineering*. Hoboken, NJ, USA: John Wiley & Sons, 2009.
- [2] Global O-Ring and Seal, *O-Ring Groove Design Guide*. Houston, TX, USA: Global O-Ring and Seal, 2026.